

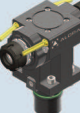





Z

ATTACCO
COUPLING
ACCOUPEMENT
KUPPLUNG

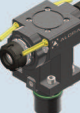



N



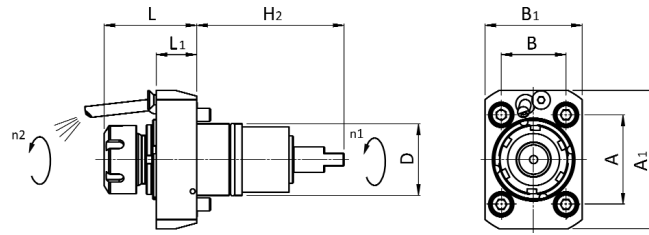

N44	Version	Tools Clamping	Center Height	Max. speed	Ratio	External	Internal	Page
	0°	ER25 - DIN6499		6000rpm	i=1:1	RAPPS 25 121UN44	RAPPS 25 131UN44	25
	90°	ER25 - DIN6499 ER25 - DIN6499	60mm 75mm	6000rpm 6000rpm	i=1:1 i=1:1	RRPPS 25 121UN44 RRPPS 25 321UN44	RRPPS 25 131UN44 RRPPS 25 331UN44	26 26
	90° Double	ER25 - DIN6499 ER25 - DIN6499	60mm 75mm	6000rpm 6000rpm	i=1:1 i=1:1	RRPPT 25 121UN44 RRPPT 25 321UN44		27 27
	±90°	ER16 - DIN6499		6000rpm	i=1:1	ROPPS 16 121UN44	ROPPS 16 131UN44	28
N55	Version	Tools Clamping	Center Height	Max. speed	Ratio	External	Internal	Page
	0°	ER25 - DIN6499 ER32 - DIN6499		6000rpm 6000rpm	i=1:1 i=1:1	RAPPS 25 121UN55 RAPPS 32 121UN55	RAPPS 25 131UN55 RAPPS 32 131UN55	25 25
	90°	ER25 - DIN6499 ER32 - DIN6499 ER25 - DIN6499 ER32 - DIN6499 ER25 - DIN6499 ER32 - DIN6499	55mm 55mm 65mm 65mm 75mm 75mm	6000rpm 6000rpm 6000rpm 6000rpm 6000rpm 6000rpm	i=1:1 i=1:1 i=1:1 i=1:1 i=1:1 i=1:1	RRPPS 25 121UN55 RRPPS 32 121UN55 RRPPS 25 321UN55 RRPPS 32 321UN55 RRPPS 25 421UN55 RRPPS 32 421UN55	RRPPS 25 131UN55 RRPPS 32 131UN55 RRPPS 25 331UN55 RRPPS 32 331UN55 RRPPS 25 431UN55 RRPPS 32 431UN55	26 26 26 26 26 26
	90° Double	ER25 - DIN6499 ER32 - DIN6499 ER25 - DIN6499 ER32 - DIN6499 ER25 - DIN6499 ER32 - DIN6499	55mm 55mm 65mm 65mm 75mm 75mm	6000rpm 6000rpm 6000rpm 6000rpm 6000rpm 6000rpm	i=1:1 i=1:1 i=1:1 i=1:1 i=1:1 i=1:1	RRPPT 25 121UN55 RRPPT 32 121UN55 RRPPT 25 321UN55 RRPPT 32 321UN55 RRPPT 25 421UN55 RRPPT 32 421UN55		27 27 27 27 27 27
	±90°	ER20 - DIN6499		6000rpm	i=1:1	ROPPS 20 121UN55	ROPPS 20 131UN55	28
N65	Version	Tools Clamping	Center Height	Max. speed	Ratio	External	Internal	Page
	0°	ER32 - DIN6499		6000rpm	i=1:1	RAPPS 32 121UN65	RAPPS 32 131UN65	25
	90°	ER32 - DIN6499 ER32 - DIN6499	65mm 80mm	6000rpm 6000rpm	i=1:1 i=1:1	RRPPS 32 121UN65 RRPPS 32 321UN65	RRPPS 32 131UN65 RRPPS 32 331UN65	26 26
	90° Double	ER32 - DIN6499 ER32 - DIN6499	65mm 80mm	6000rpm 6000rpm	i=1:1 i=1:1	RRPPT 32 121UN65 RRPPT 32 321UN65		27 27
	±90°	ER25 - DIN6499		6000rpm	i=1:1	ROPPS 25 121UN65	ROPPS 25 131UN65	28

N

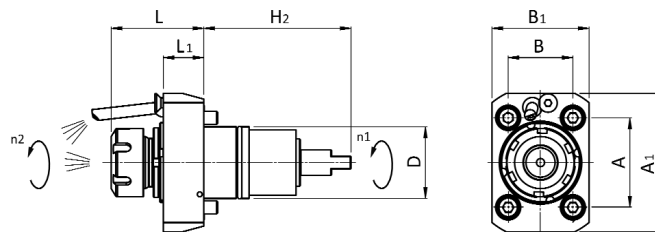

1/N		Codice code - code - Bestell Nr.	D	ER	H	H1	H2	L (min-max)	L1	L2	A	B	A1	B1	A2	B2	M ₂ Nm	n ₂ min-1	P kW
0°	 DIN 6499	 +1 (1:1)	RAPPS 25 121UN44	44	25		91	53,5÷57,2	25		55	40	85	60			40	6000	6
			RAPPS 25 121UN55	55	25		108	53,5÷57,2	25		60	50	84	79				63	6000
 EXTERNAL			RAPPS 32 121UN55	55	32		108	68,5÷72,2	32		60	50	84	79			63	6000	10
			RAPPS 32 121UN65	65	32		115,5	74,2÷77,9	38,5		71	69	92	100				63	6000

N

2/N		Codice code - code - Bestell Nr.	D	ER	H	H1	H2	L (min-max)	L1	L2	A	B	A1	B1	A2	B2	M ₂ Nm	n ₂ min-1	P kW
0°	 DIN 6499	 +1 (1:1)	RAPPS 25 131UN44	44	25		91	53,5÷57,2	25		55	40	85	60			40	6000	6
			RAPPS 25 131UN55	55	25		108	53,5÷57,2	25		60	50	84	79				63	6000
 INT./EXT.	 70 bar	 Filtration 30µm	RAPPS 32 131UN55	55	32		108	68,5÷72,2	32		60	50	84	79			63	6000	10
			RAPPS 32 131UN65	65	32		115,5	74,2÷77,9	38,5		71	69	92	100				63	6000

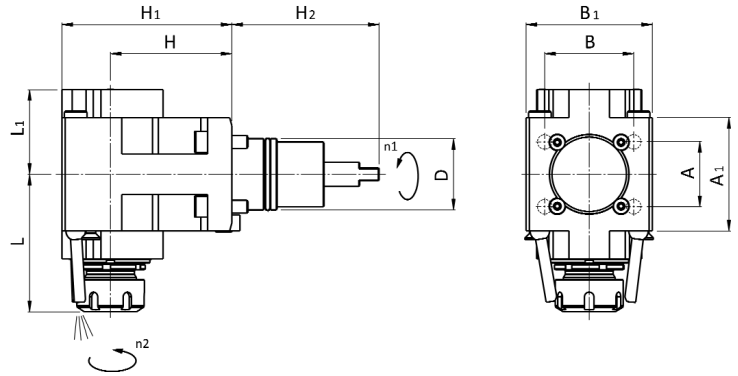



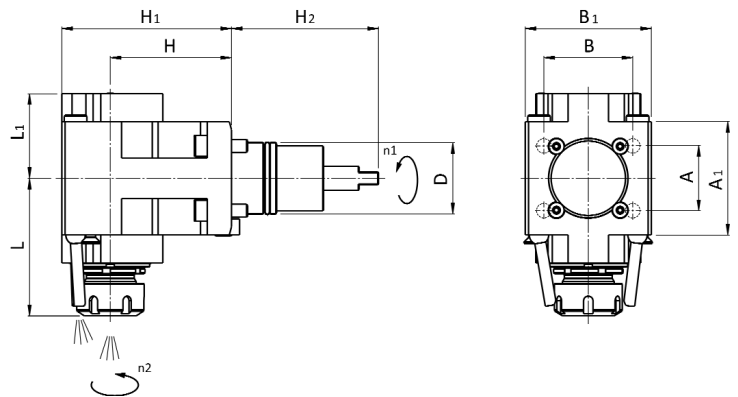

3/N			Codice code - code - Bestell Nr.	D	ER	H	H1	H2	L (min-max)	L1	L2	A	B	A1	B1	A2	B2	M ₂ Nm	n ₂ min-1	P kW
90°			RRPPS 25 121UN44	44	25	60	90	91	81,2-84,9	52,2		40	55	70	78			40	6000	6
			RRPPS 25 321UN44	44	25	75	105	91	81,2-84,9	52,2		40	55	70	78			40	6000	6
			RRPPS 25 121UN55	55	25	55	87	108	82,5-86,2	57,4		50	60	80	84			63	6000	10
			RRPPS 32 121UN55	55	32	55	87	108	90-93,7	57,4		50	60	80	84			63	6000	10
			RRPPS 25 321UN55	55	25	65	97	108	82,5-86,2	57,4		50	60	80	84			63	6000	10
			RRPPS 32 321UN55	55	32	65	97	108	90-93,7	57,4		50	60	80	84			63	6000	10
			RRPPS 25 421UN55	55	25	75	107	108	82,5-86,2	57,4		50	60	80	84			63	6000	10
			RRPPS 32 421UN55	55	32	75	107	108	90-93,7	57,4		50	60	80	84			63	6000	10
			RRPPS 32 121UN65	65	32	65	103	115,5	90,2-93,9	54,5		69	71	100	92			63	6000	10
			RRPPS 32 321UN65	65	32	80	118	115,5	90,2-93,9	54,5		69	71	100	92			63	6000	10

N

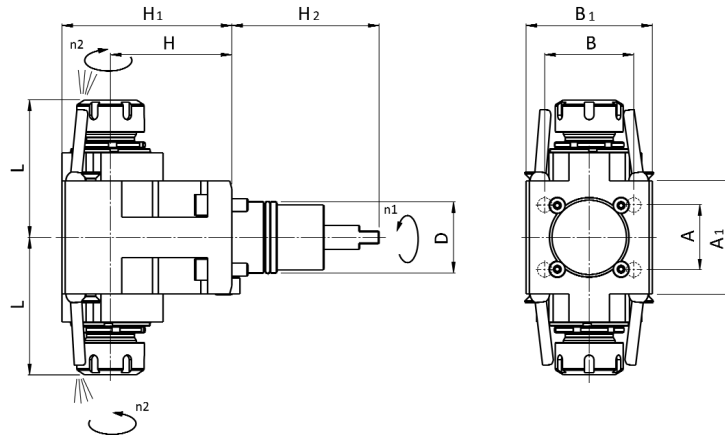
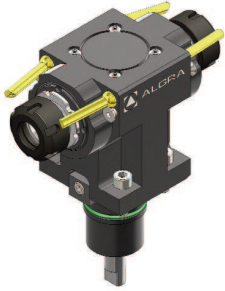





4/N			Codice code - code - Bestell Nr.	D	ER	H	H1	H2	L (min-max)	L1	L2	A	B	A1	B1	A2	B2	M ₂ Nm	n ₂ min-1	P kW
90°			RRPPS 25 131UN44	44	25	60	90	91	81,2-84,9	52,2		40	55	70	78			40	6000	6
			RRPPS 25 331UN44	44	25	75	105	91	81,2-84,9	52,2		40	55	70	78			40	6000	6
			RRPPS 25 131UN55	55	25	55	87	108	82,5-86,2	63,4		50	60	80	84			63	6000	10
			RRPPS 32 131UN55	55	32	55	87	108	90-93,7	63,4		50	60	80	84			63	6000	10
			RRPPS 25 331UN55	55	25	65	97	108	82,5-86,2	63,4		50	60	80	84			63	6000	10
			RRPPS 32 331UN55	55	32	65	97	108	90-93,7	63,4		50	60	80	84			63	6000	10
			RRPPS 25 431UN55	55	25	75	107	108	82,5-86,2	63,4		50	60	80	84			63	6000	10
			RRPPS 32 431UN55	55	32	75	107	108	90-93,7	63,4		50	60	80	84			63	6000	10
			RRPPS 32 131UN65	65	32	65	103	115,5	90,2-93,9	64,5		69	71	100	92			63	6000	10
			RRPPS 32 331UN65	65	32	80	118	115,5	90,2-93,9	64,5		69	71	100	92			63	6000	10

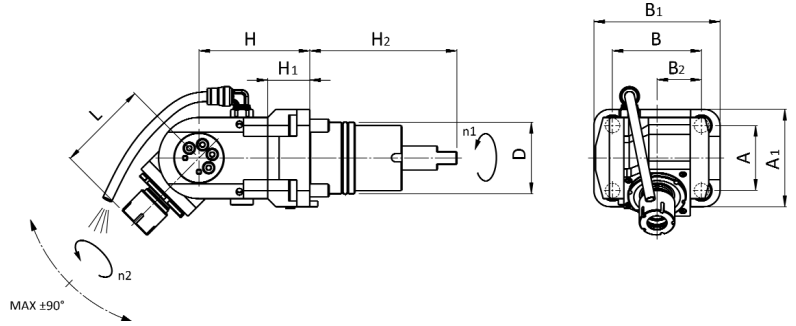





5/N		Codice code - code - Bestell Nr.	D	ER	H	H1	H2	L (min-max)	L1	L2	A	B	A1	B1	A2	B2	M ₂ Nm	n ₂ min-1	P kW		
90°	 DIN 6499	 ±1 (1:1)	RRPPT 25 121UN44	44	25	60	90	91	81,2-84,9			40	55	70	78			40	6000	6	
			RRPPT 25 321UN44	44	25	75	105	91	81,2-84,9				40	55	70	78			40	6000	6
 EXTERNAL			RRPPT 25 121UN55	55	25	55	87	108	82,5-86,2			50	60	80	84			63	6000	10	
			RRPPT 32 121UN55	55	32	55	87	108	90-93,7				50	60	80	84			63	6000	10
			RRPPT 25 321UN55	55	25	65	97	108	82,5-86,2				50	60	80	84			63	6000	10
			RRPPT 32 321UN55	55	32	65	97	108	90-93,7				50	60	80	84			63	6000	10
			RRPPT 25 421UN55	55	25	75	107	108	82,5-86,2				50	60	80	84			63	6000	10
			RRPPT 32 421UN55	55	32	75	107	108	90-93,7				50	60	80	84			63	6000	10
			RRPPT 32 121UN65	65	32	65	103	115,5	90,2-93,9			69	71	100	92			63	6000	10	
			RRPPT 32 321UN65	65	32	80	118	115,5	90,2-93,9			69	71	100	92			63	6000	10	

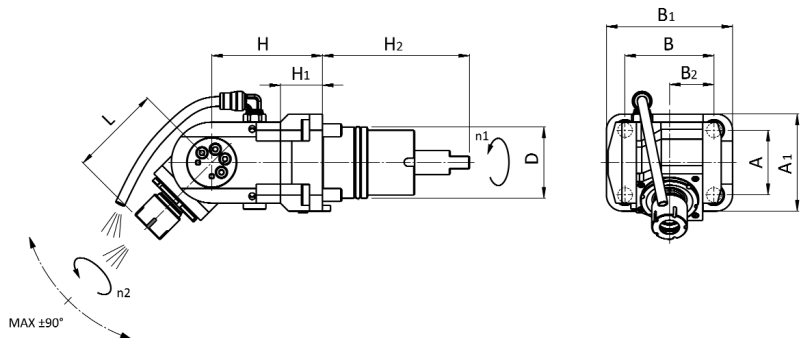

6/N			Codice code - code - Bestell Nr.	D	ER	H	H1	H2	L (min-max)	L1	L2	A	B	A1	B1	A2	B2	M ₂ Nm	n ₂ min-1	P kW
    EXTERNAL			ROPPS 16 121UN44	44	16	68,5	26	91	52,8-56,5			40	55	60	78		27,5	10	6000	2
			ROPPS 20 121UN55	55	20	71	18	108	48,8-52,5			50	60	80	84		30	15	6000	3
			ROPPS 25 121UN65	65	25	80	17	115,5	63,5-67,2			69	71	100	92		35,5	25	6000	4

N

7/N			Codice code - code - Bestell Nr.	D	ER	H	H1	H2	L (min-max)	L1	L2	A	B	A1	B1	A2	B2	M ₂ Nm	n ₂ min-1	P kW
    INT./EXT.			ROPPS 16 131UN44	44	16	68,5	26	91	52,8-56,5			40	55	60	78		27,5	10	6000	2
			ROPPS 20 131UN55	55	20	71	18	108	48,8-52,5			50	60	80	84		30	15	6000	3
			ROPPS 25 131UN65	65	25	80	17	115,5	63,5-67,2			69	71	100	92		35,5	25	6000	4